



**YANMECH**  
YANMECH Industrial Co., Ltd.

YANMECH Industrial Co., Ltd.

Tel: +886-4-22715886

Fax: +886-4-22712200

Mail: [jheyang@gmail.com](mailto:jheyang@gmail.com)

Web: [www.yanmech.com.tw](http://www.yanmech.com.tw)

Tax ID: 23536862

Add: No.2, Gongye 19th Rd., Taiping Dist., Taichung City 411, Taiwan (R.O.C.)



# CONTENTS

	01	YANMECH Introduction
	02	Mechanical Equipment
	<b>D</b> series	04 Closed Center High Precision Power Chucks
	<b>A</b> series	06 Closed Center High Precision Power Chucks (manual setting)
	<b>J</b> series	09 Closed Center Independent Chucks
	<b>L</b> series	09 Independent Chucks
	<b>I</b> series	10 Self-Centering Scroll Chucks
	<b>G</b> series	11 Closed Center Self-Centering Scroll Chucks
	<b>TB</b> series	12 Closed Center Hydraulic Cylinder (BUILT-IN CHECK VALVE)
	<b>TC</b> series	13 Closed Center Hydraulic Cylinder (BUILT-IN CHECK VALVE & SWITCH BRACKETS)
	<b>M</b> series	14 Box Jaws (4pcs/ set)
	<b>PD</b> series	16 Hard Top Jaws
	<b>PE</b> series	18 Soft Top Jaws
	<b>PM</b> series	20 Adapter Plates
	<b>PK</b> series	21 T-Nuts
<b>PK5</b> series	21	T-Screws



## YANMECH Industrial

YANMECH Has established for a nearly three decades to processing all kinds of precision Machinery parts for the best quality of the industry at home and a board between the deep affirmation. The company is equipped with lathe, milling, self processing grinder, and also with various precision/coordinate measuring machines to ensure all requirements are met precisely.

We have accumulated the best experience in developing and manufacturing various high quality product chucks in years, including Large Hydraulic Chucks, Medium and Hollow manual interlocking chucks, Box Jaws, Rotary Hydraulic Cylinders, and etc. We strive to grow our concept with the highest precision and quality.

# MACHINERY EQUIPMENT



Coordinate  
Measuring Machine

CNC Vertical Lathe



CNC Vertical Lathe



Coordinate Measuring Machine



CNC Vertical Machining Center



CNC Horizontal Lathe



Coordinate Measuring Machine



Coordinate Measuring Machine



CNC Vertical Machining Center



CNC Horizontal Lathe

# D series

## CLOSED CENTER HIGH PRECISION POWER CHUCKS



- Install side strips and chips cover sealed base jaw to prevent chips and coolant ingress.
- Adapter Plates can be selected.

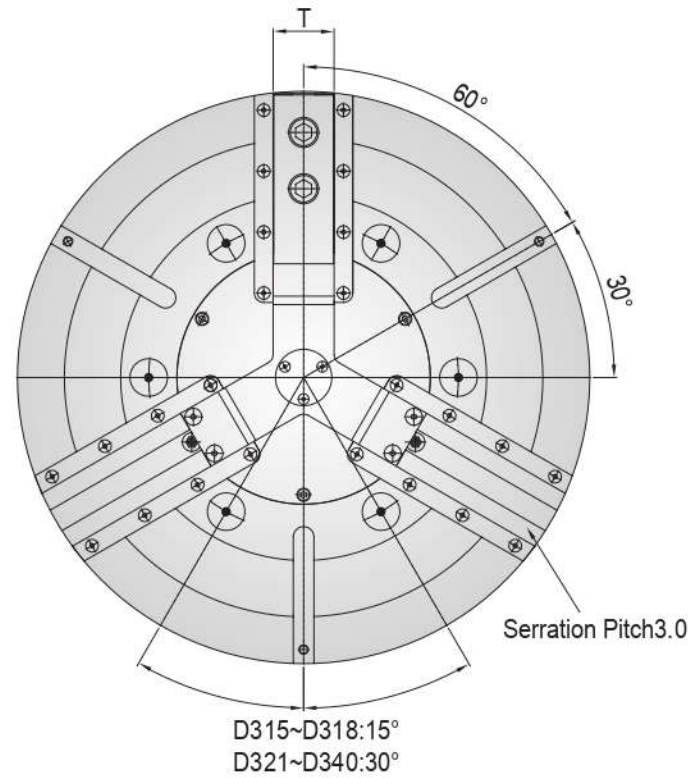

- The base jaw is lower than the body surface and can be used for multipurpose.
- Alternative spindle adaptors:  
ASA or DIN adaptors can be supplied as requested.

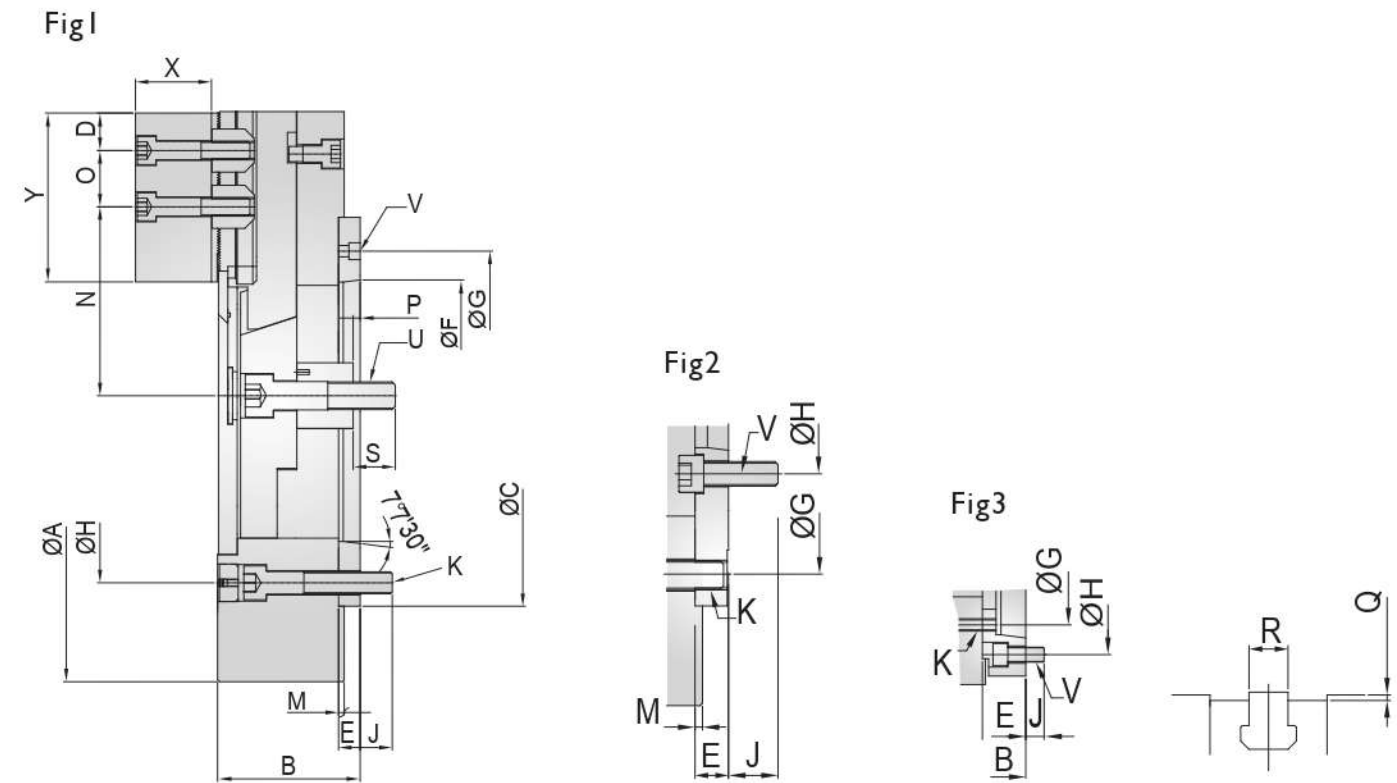

### SPECIFICATION

Model	Adaptor	Plunger Stroke(mm)	Jaw Stroke [Diameter] (mm)	MAX.PUSH FORCE (kgf)	Max. Gripping Force (kgf)	Max. Hydr. Pressure (kgf/cm <sup>2</sup> )	Max. Speed (r.p.m.)	Weight (kg)	Moment Of Inertia (kg.m <sup>2</sup> )	Cylinders	Hard Top Jaws	Soft Top Jaws	Gripping Range (Ømm)
D315	A8	35	11.3	8311	25340	32.5	3000	137	2.1	TC20035	PD1-15-1	PE1-15-2	Ø62-Ø392
D315	A11	35	11.3	8311	25340	32.5	3000	126	2	TC20035	PD1-15-1	PE1-15-2	Ø62-Ø392
D315	A15	35	11.3	8311	25340	32.5	3000	150	2.3	TC20035	PD1-15-1	PE1-15-2	Ø62-Ø392
D318	A8	35	11.3	8311	25340	32.5	2700	157	3.4	TC20035	PD1-15-1	PE1-24-1	Ø62-Ø461
D318	A11	35	11.3	8311	25340	32.5	2700	143	3.1	TC20035	PD1-15-1	PE1-24-1	Ø62-Ø461
D318	A15	35	11.3	8311	25340	32.5	2700	167	3.6	TC20035	PD1-15-1	PE1-24-1	Ø62-Ø461
D321	A11	35	11.3	8506	27419	33.5	1920	234	6.6	TC20035	PD1-21-1	PE1-24-1	Ø102-Ø541
D321	A15	35	11.3	8506	27419	33.5	1920	226	6.4	TC20035	PD1-21-1	PE1-24-1	Ø102-Ø541
D324	A11	35	11.3	8506	27419	33.5	1730	280	7.7	TC20035	PD1-21-1	PE1-24-1	Ø102-Ø621
D324	A15	35	11.3	8506	27419	33.5	1730	271	7.4	TC20035	PD1-21-1	PE1-24-1	Ø102-Ø621
D332	A11	35	11.3	8506	27419	33.5	605	447	31	TC20035	PD1-32-1	PE1-32-1	Ø147-Ø811
D332	A15	35	11.3	8506	27419	33.5	605	439	29	TC20035	PD1-32-1	PE1-32-1	Ø147-Ø811
D340	A15	57	18.5	18354	32630	42.75	600	650	83	TC25060	PD1-40-1	PE1-40-1	Ø112-Ø1000
D340	A20	57	18.5	18354	32630	42.75	600	642	81	TC25060	PD1-40-1	PE1-40-1	Ø112-Ø1000

• If the dimension and specification change, please take the confirmation drawing as a standard.

### DIMENSIONS

Model	Adaptor	A	B	C	D	E	F	G	H	J	K	M	N (max)	O (max)	O (min)	P (down)	P (up)	Q	R	S	T	U	V	X	Y	Reference Drawing
D315	A8	381	162	300	43	33	139.719	235	171.45	25	6-M20	6	77.5	50	24	-4.5	30.5	2	25	58.5	64	M30*3.5P	6-M16	67.5	160	Fig2
D315	A11	381	151	300	43	22	196.869	260	235	29	6-M20	6	77.5	50	24	-15.5	19.5	2	25	58.5	64	M30*3.5P	3-M12	67.5	160	Fig1
D315	A15	381	186	300	43	57	285.775	235	330.2	25	6-M20	6	77.5	50	24	19.5	54.5	2	25	58.5	64	M30*3.5P	6-M24	67.5	160	Fig3
D318	A8	450	162	300	43	33	139.719	235	171.45	25	6-M20	6	108	50	24	-4.5	30.5	0.5	25	58.5	64	M30*3.5P	6-M16	67.5	180	Fig2
D318	A11	450	151	300	43	22	196.869	260	235	29	6-M20	6	108	50	24	-15.5	19.5	0.5	25	58.5	64	M30*3.5P	3-M12	67.5	180	Fig1
D318	A15	450	186	300	43	57	285.775	235	330.2	25	6-M20	6	108	50	24	19.5	54.5	0.5	25	58.5	64	M30*3.5P	6-M24	67.5	180	Fig3
D321	A11	530	156	380	60	27	196.869	330.2	235	31	6-M24	6	83	98	29	-7.5	27.5	0.5	25	60	64	M30*3.5P	6-M20	67.5	180	Fig2
D321	A15	530	156	380	60	27	285.775	330.2	330.2	35	6-M24	6	83	98	29	-7.5	27.5	0.5	25	60	64	M30*3.5P	3-M12	67.5	180	Fig1
D324	A11	610	156	380	60	27	196.869	330.2	235	31	6-M24	6	122	98	29	-7.5	27.5	0.5	25	60	64	M30*3.5P	6-M20	67.5	180	Fig2
D324	A15	610	156	380	60	27	285.775	330.2	330.2	35	6-M24	6	122	98	29	-7.5	27.5	0.5	25	60	64	M30*3.5P	3-M12	67.5	180	Fig1
D332	A11	800	166	380	80	27	196.869	330.2	235	31	6-M24	6	102	201	30	-24	11	2	25	60	74	M30*3.5P	6-M20	86	210	Fig2
D332	A15	800	166	380	80	27	285.775	330.2	330.2	35	6-M24	6	102	201	30	-24	11	2	25	60	74	M30*3.5P	3-M12	86	210	Fig1
D340	A15	1000	180	520	80	27	285.775	330.2	463.6	51	6-M24	8	345	300	60	-44.5	12.5	2	25	60	85	M36*4P	6-M24	88	180	Fig2
D340	A20	1000	180	520	80	25	412.775	463.6	463.6	55	6-M24	8	345	300	60	-44.5	12.5	2	25	60	85	M36*4P	3-M16	88	180	Fig1

• If the dimension and specification change, please take the confirmation drawing as a standard.

# A series

## CLOSED CENTER HIGH PRECISION POWER CHUCKS (MANUAL SETTING)



- The jaw can be individually operated, and irregularly shaped workpieces can be clamped.
- Install side strips and chips cover sealed base jaw to prevent chips and coolant ingress.

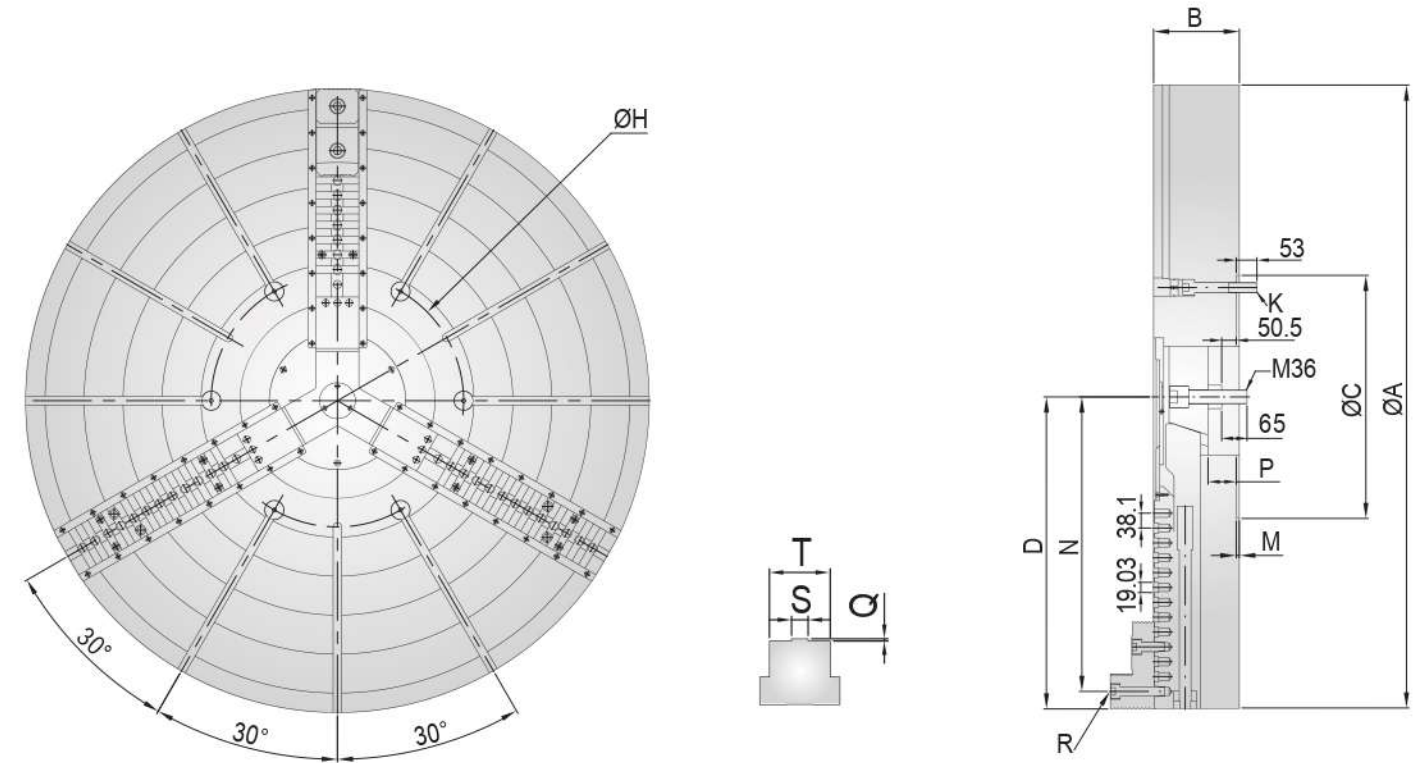

### SPECIFICATION

Model	Number Of Jaws	Plunger Stroke (mm)	Jaw Stroke [manual setting] (mm)	Max. Push Force (kgf)	Max. Gripping Force (kgf)	Max. Hydr. Pressure (kgf/cm <sup>2</sup> )	Max. Speed (r.p.m.)	Weight (kg)	Moment Of Inertia (kgf.m <sup>2</sup> )	Cylinders	Hard Top Jaws	Soft Top Jaws
A340Z520	3	57	18.5	18354	32600	42.75	630	650	83	TC25060	PD2-40-1	PE2-40
AP340Z520	3	57	18.5+(30)	18354	32600	42.75	630	650	83	TC25060	PD2-40-1	PE2-40
A440Z520	4	57	18.5	18354	32600	42.75	570	705	90	TC25060	PD2-40-1	PE2-40
AP440Z520	4	57	18.5+(30)	18354	32600	42.75	570	705	90	TC25060	PD2-40-1	PE2-40
A640Z520	6	57	18.5	18354	32600	42.75	450	815	97	TC25060	PD2-40-1	PE2-40
AP640Z520	6	57	18.5+(30)	18354	32600	42.75	450	815	97	TC25060	PD2-40-1	PE2-40
A350Z520	3	57	18.5	18354	32600	42.75	500	895	169	TC25060	PD2-50-1	PE2-40
AP350Z520	3	57	18.5+(30)	18354	32600	42.75	500	895	169	TC25060	PD2-50-1	PE2-40
A450Z520	4	57	18.5	18354	32600	42.75	450	945	178	TC25060	PD2-50-1	PE2-40
AP450Z520	4	57	18.5+(30)	18354	32600	42.75	450	945	178	TC25060	PD2-50-1	PE2-40
A650Z520	6	57	18.5	18354	32600	42.75	360	1045	187	TC25060	PD2-50-1	PE2-40
AP650Z520	6	57	18.5+(30)	18354	32600	42.75	360	1045	187	TC25060	PD2-50-1	PE2-40
A363Z720	3	60	19.5	20394	36700	46.85	400	1710	519	TC25060	PD2-63	PE2-63
AP363Z720	3	60	19.5+(40)	20394	36700	46.85	400	1710	519	TC25060	PD2-63	PE2-63
A463Z720	4	60	19.5	20394	36700	46.85	360	1810	549	TC25060	PD2-63	PE2-63
AP463Z720	4	60	19.5+(40)	20394	36700	46.85	360	1810	549	TC25060	PD2-63	PE2-63
A663Z720	6	60	19.5	20394	36700	46.85	280	2010	579	TC25060	PD2-63	PE2-63
AP663Z720	6	60	19.5+(40)	20394	36700	46.85	280	2010	579	TC25060	PD2-63	PE2-63
AP479Z720	4	60	19.5+(40)	20394	36700	46.85	300	3300	1250	TC25060	PD2-79	PE2-79
AP679Z720	6	60	19.5+(40)	20394	36700	46.85	230	3720	1295	TC25060	PD2-79	PE2-79
AP498Z720	4	60	19.5+(40)	20394	36700	46.85	220	5060	2002	TC25060	PD2-98	PE2-98
AP698Z720	6	60	19.5+(40)	20394	36700	46.85	180	5200	2058	TC25060	PD2-98	PE2-98

• If the dimension and specification change, please take the confirmation drawing as a standard.

### DIMENSIONS

Model	A	B	C (H6)	D	H	K	M	N (max)	P (max)	P (min)	Q	R	S	T
A340Z520	1000	180	520	496	463.6	M24	8	478	62	5	4	M24	30	85
AP340Z520	1000	180	520	496	463.6	M24	8	478	62	5	4	M24	30	85
A440Z520	1000	180	520	496	463.6	M24	8	478	62	5	4	M24	30	85
AP440Z520	1000	180	520	496	463.6	M24	8	478	62	5	4	M24	30	85
A640Z520	1000	180	520	496	463.6	M24	8	478	62	5	4	M24	30	85
AP640Z520	1000	180	520	496	463.6	M24	8	478	62	5	4	M24	30	85
A350Z520	1250	180	520	623	463.6	M24	8	578.5	62	5	4	M24	30	85
AP350Z520	1250	180	520	623	463.6	M24	8	578.5	62	5	4	M24	30	85
A450Z520	1250	180	520	623	463.6	M24	8	578.5	62	5	4	M24	30	85
AP450Z520	1250	180	520	623	463.6	M24	8	578.5	62	5	4	M24	30	85
A650Z520	1250	180	520	623	463.6	M24	8	578.5	62	5	4	M24	30	85
AP650Z520	1250	180	520	623	463.6	M24	8	578.5	62	5	4	M24	30	85
A363Z720	1600	210	720	795	647.6	M30(M24)	8	755	85	23	4	M24	30	110
AP363Z720	1600	210	720	795	647.6	M30(M24)	8	755	85	23	4	M24	30	110
A463Z720	1600	210	720	795	647.6	M30(M24)	8	755	85	23	4	M24	30	110
AP463Z720	1600	210	720	795	647.6	M30(M24)	8	755	85	23	4	M24	30	110
A663Z720	1600	210	720	795	647.6	M30(M24)	8	755	85	23	4	M24	30	110
AP663Z720	1600	210	720	795	647.6	M30(M24)	8	755	85	23	4	M24	30	110
AP479Z720	2000	240	720	995	647.6	M30	8	965	95.5	21.5	4	M24	30	110
AP679Z720	2000	240	720	995	647.6	M30	8	965	95.5	21.5	4	M24	30	110
AP498Z720	2500	250	720	1245	647.6	M30	8	1195	105.5	31.5	4	M24	30	110
AP698Z720	2500	250	720	1245	647.6	M30	8	1195	105.5	31.5	4	M24	30	110

• If the dimension and specification change, please take the confirmation drawing as a standard.

# J series

## CLOSED CENTER INDEPENDENT CHUCKS



- Forged steel body.
- Adapter Plates can be selected.
- Install side strips and chips cover sealed base jaw to prevent chips and coolant ingress.
- The jaw can be individually operated, and irregularly shaped workpieces can be clamped.
- Special specifications can be customized.

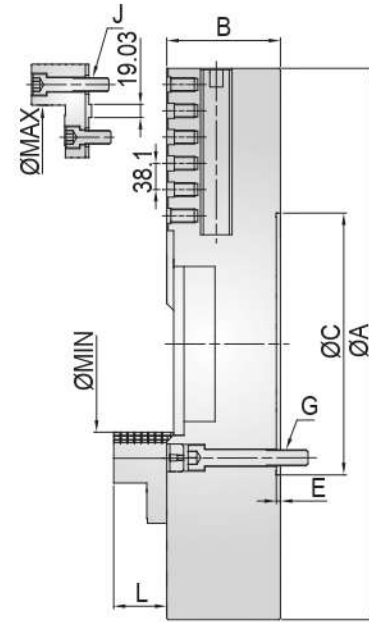
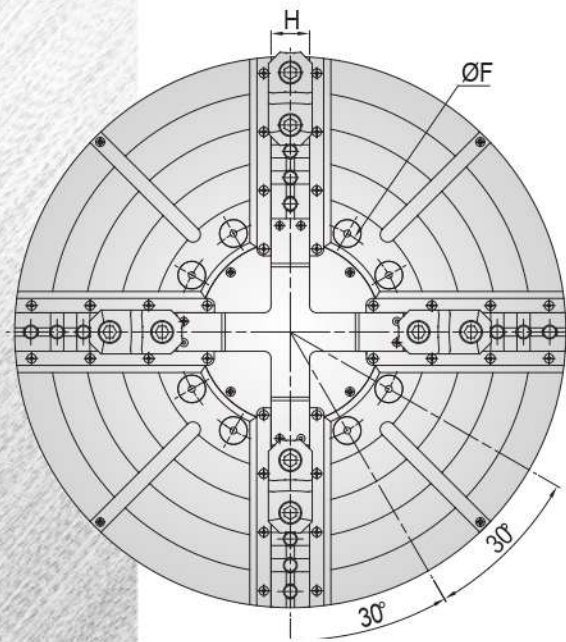

Model	A	B	C (H6)	E	F	G	H	L	J	Gripping Range(Ømm)		Max. Speed (r.p.m.)	Max. Gripping Force (kgf)	Adaptor
										(min)	(max)			
J421Z380	530	146	380	8	330.2	8-M24	56	77	M20	125	430	1300	11500	PM1A15
J421Z380	530	146	380	8	330.2	8-M24	56	77	M20	125	430	1300	11500	PM2A11
J424Z380	610	155	380	8	330.2	8-M24	56	77	M20	168	480	900	13500	PM1A15
J424Z380	610	155	380	8	330.2	8-M24	56	77	M20	168	480	900	13500	PM2A11
J432Z380	800	165	380	8	330.2	8-M24	56	77	M20	231	695	750	17500	PM1A15
J432Z380	800	165	380	8	330.2	8-M24	56	77	M20	231	695	750	17500	PM2A11
J440Z520	1000	180	520	8	463.6	8-M24	80	80	M24	288	880	550	17500	PM1A20
J440Z520	1000	180	520	8	463.6	8-M24	80	80	M24	288	880	550	17500	PM2A15
J450Z520	1250	200	520	8	463.6	8-M24	80	100	M24	288	1128	420	21500	PM1A20
J450Z520	1250	200	520	8	463.6	8-M24	80	100	M24	288	1128	420	21500	PM2A15
J463Z720	1600	200	720	8	647.6	8-M30	80	100	M24	420	1480	380	26500	PM1A20

• If the dimension and specification change, please take the confirmation drawing as a standard.

# L series

## INDEPENDENT CHUCKS



- Forged steel body.
- Adapter Plates can be selected.
- The jaw can be individually operated, and irregularly shaped workpieces can be clamped.
- Special specifications can be customized.

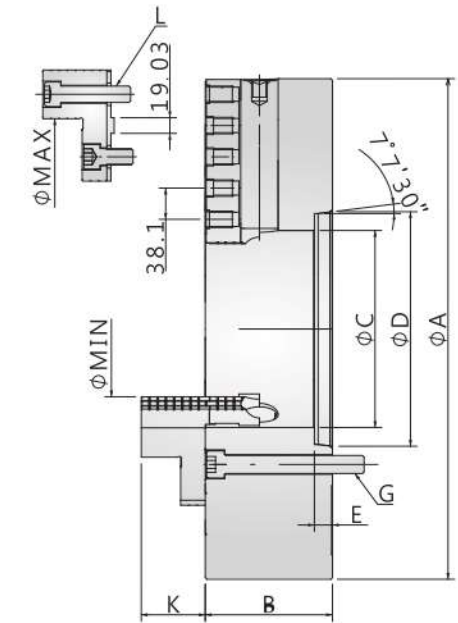
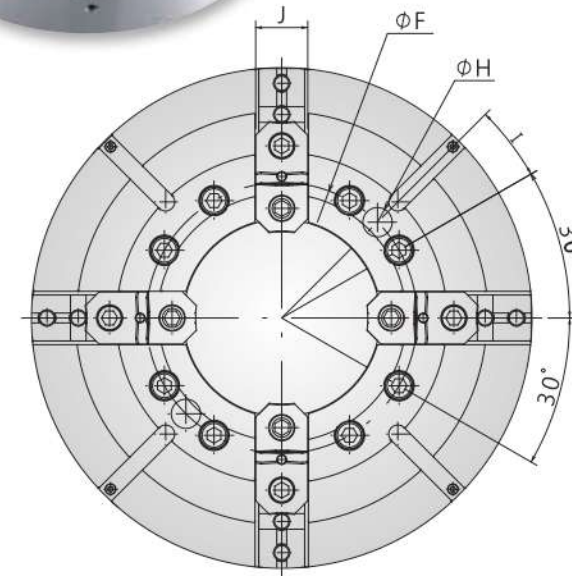

Model	A	B	C	D	E	F	G	H	I	J	K	L	Max. Speed (r.p.m.)	Max. Gripping Force (kgf)	Spindle Noses
L421U11	530	135	120	196.869	23	235	8-M20	29.4	30	56	89	M20	1300	12500	A2-11
L421U15	530	135	200	285.775	24	330.2	8-M24	35.7	15	56	89	M20	1300	12500	A2-15
L424U11	610	135	120	196.869	23	235	8-M20	29.4	30	56	89	M20	900	15000	A2-11
L424U15	610	135	235	285.775	24	330.2	8-M24	35.7	15	56	89	M20	900	15000	A2-15
L424U20	610	135	310	412.775	25	463.6	8-M24	42.1	15	56	89	M20	900	15000	A2-20
L428U11	700	140	120	196.869	23	235	8-M20	29.4	30	56	89	M20	870	15000	A2-11
L428U15	700	140	235	285.775	24	330.2	8-M24	35.7	15	56	89	M20	870	15000	A2-15
L428U20	700	140	385	412.775	25	463.6	8-M24	42.1	15	56	89	M20	870	15000	A2-20
L432U11	800	145	120	196.869	23	235	8-M20	29.4	30	56/75	89/92	M20/M24	650	19000	A2-11
L432U15	800	145	235	285.775	24	330.2	8-M24	35.7	15	56/75	89/92	M20/M24	650	19000	A2-15
L432U20	800	145	385	412.775	25	463.6	8-M24	42.1	15	56/75	89/92	M20/M24	650	19000	A2-20
L440U15	1000	150	235	285.775	24	330.2	8-M24	35.7	15	56/75	89/92	M20/M24	550	19000	A2-15
L440U20	1000	150	385	412.775	25	463.6	8-M24	42.1	15	56/75	89/92	M20/M24	550	19000	A2-20
L450U15	1250	190	235	285.775	24	330.2	8-M24	35.7	15	80	122	M24	420	23000	A2-15
L450U20	1250	190	385	412.775	25	463.6	8-M24	42.1	15	80	122	M24	420	23000	A2-20
L463U20	1600	210	385	412.775	25	463.6	8-M24	42.1	15	90	117	M24	380	28000	A2-20

• If the dimension and specification change, please take the confirmation drawing as a standard.

# I series

## SELF CENTERING SCROLL CHUCKS



- Cast iron or forged steel body.
- High accuracy of repeated positioning.
- Special specifications can be customized.

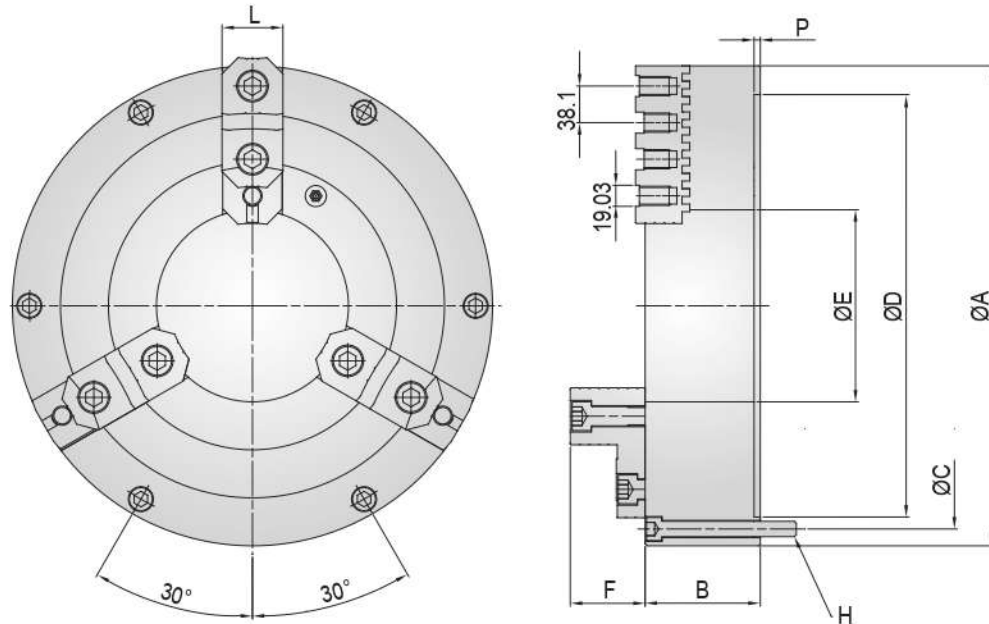

# G series

## CLOSED CENTER SELF-CENTERING SCROLL CHUCKS

- Cast iron or forged steel body.
- Install side strips and chips cover sealed base jaw to prevent chips and coolant ingress.
- High accuracy of repeated positioning.
- Special specifications can be customized.

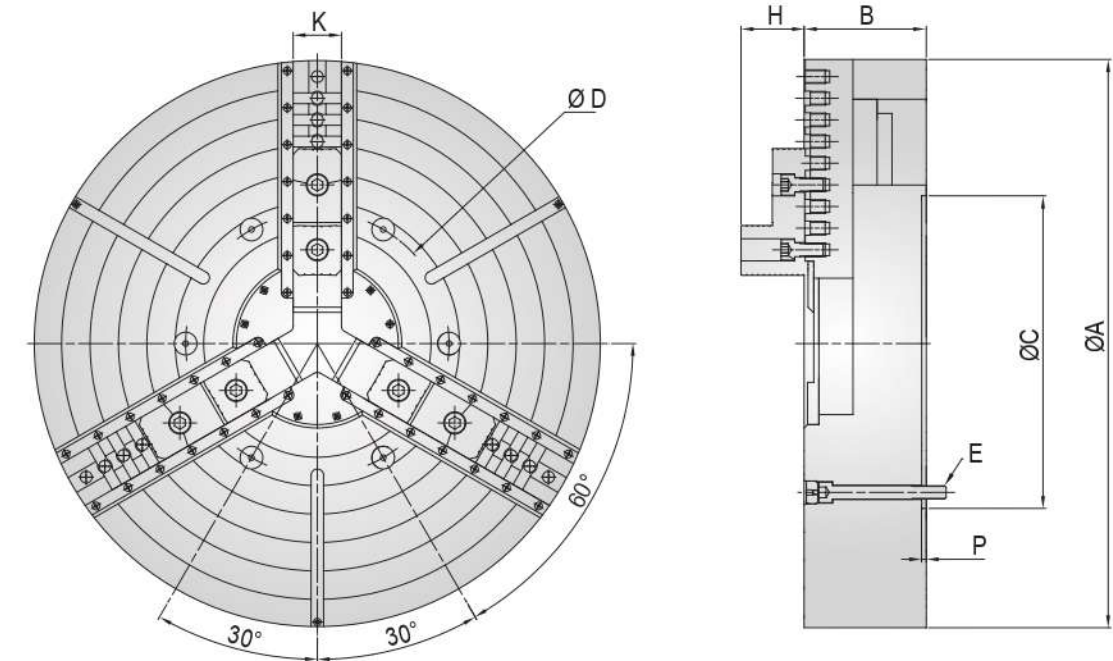

Model	A	B	C	D (H6)	E	F	H	L	P	Max. Gripping Force (kgf)	Gripping Range (Ømm)		Max. Speed (r.p.m.)	Weight (kg)
											(min)	(max)		
I320Z440	500	120	465	440	200	89	6-M16	62	6	7400	35	500	1000	135
I324Z545	630	140	586	545	205	89	6-M16	62	6	8200	55	630	900	242
I328Z620	700	175	660	620	240	92	6-M20	85	8	8500	55	700	650	380
I332Z720	800	175	760	720	360	92	6-M20	85	8	8700	60	800	550	450
I336Z810	915	175	850	810	375	92	6-M24	85	8	8700	80	915	450	585
I340Z910	1000	175	950	910	535	92	6-M24	85	8	9100	340	1000	400	620
I350Z910	1250	185	950	910	535	92	6-M24	85	8	9100	240	1250	350	1200

• If the dimension and specification change, please take the confirmation drawing as a standard.

Model	A	B	C (H6)	D	E	H	K	P	Max. Gripping Force (kgf)	Gripping Range (Ømm)		Gripping Range [Inside] (Ømm)		Max. Speed (r.p.m.)	Weight (kg)
										(min)	(max)	(min)	(max)		
G320Z440	500	140	440	465	6-M16	78	62	6	7300	160	475	270	490	950	195
G324Z545	630	167	545	586	6-M20	78	62	6	7500	160	530	275	490	800	380
G328Z620	700	190	620	660	6-M20	80	85	8	7500	205	585	340	545	600	560
G332Z380	800	190	380	330.2	6-M24	80	74	8	7500	220	685	375	660	560	615
G336Z380	915	200	380	330.2	6-M24	80	74	8	8000	220	840	355	810	480	843
G340Z520	1000	215	520	463.6	6-M24	92	85	8	8000	220	905	595	875	400	1010
G350Z520	1250	220	520	463.6	6-M24	92	85	8	8500	290	1080	350	1100	360	1550

• If the dimension and specification change, please take the confirmation drawing as a standard.

# TB series

## CLOSED CENTER HYDRAULIC CYLINDER (BUILT-IN CHECK VALVE)



- Built-in check valve.

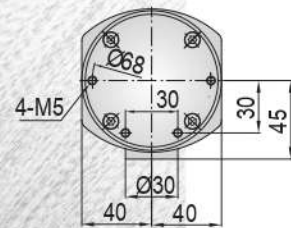
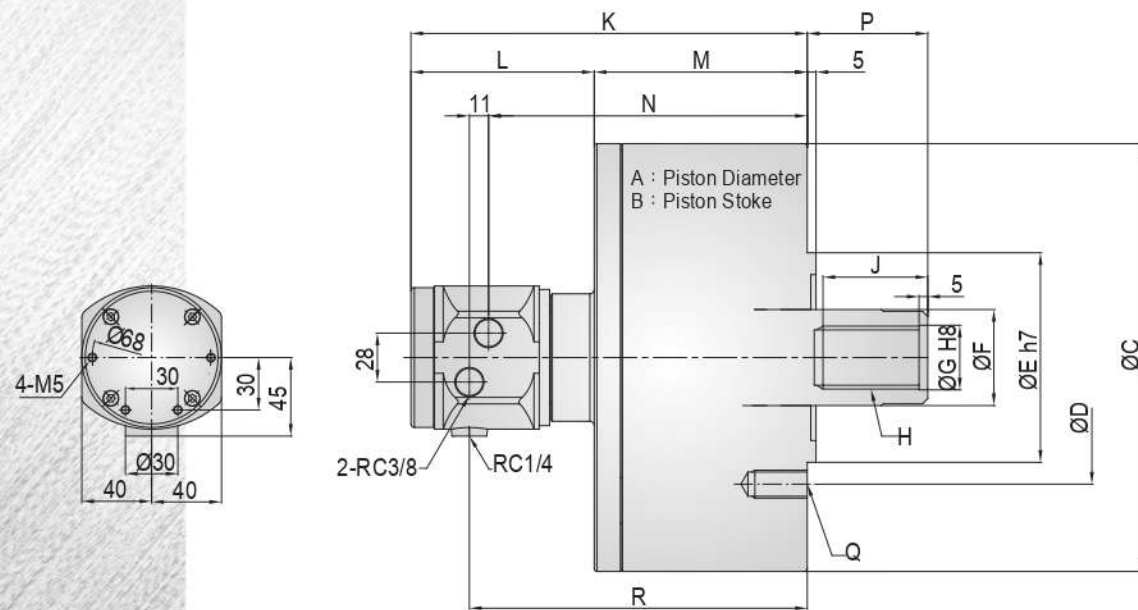

### SPECIFICATION

Model	Piston Area		Max. Push Force (kgf)	Max. Hydr. Pressure (kgf/cm <sup>2</sup> )	Oil Leakage Rate (l/min)	Max. Speed (r.p.m.)	Weight (kg)	Moment Of Inertia (kg.m <sup>2</sup> )
	Push Side (cm <sup>2</sup> )	Pull Side (cm <sup>2</sup> )						
TB10520	87	80	2960	41	0.8	6,000	8	0.013
TB12525	123	114	4285	41	0.8	6,000	11	0.023
TB15030	177	161	6120	41	0.8	5,500	14	0.048
TB20035	315	291	11015	41	0.8	5,500	36.5	0.122

• Push Force : Hydr. Pressure 41kgf/cm<sup>2</sup>

• Oil Leakage Rate : Hydr. Pressure 30.6kgf/cm<sup>2</sup> and 50°C

### DIMENSIONS

Model	A Piston Diameter	B Piston Stroke	C	D	E (h7)	F	G (H8)	H	J	K	L	M	N	P (max)	P (min)	Q	R
TB10520	105	20	135	100	80	30	21	M20x2.5	35	197	105	89	152.5	45	25	M10x1.5	162.5
TB12525	125	25	160	130	110	35	25	M24x3.0	44	205	105	99	159.5	51	26	M12x1.75	170.5
TB15030	150	30	190	130	110	45	31	M30x3.5	45	214	105	109	169.5	56	26	M12x1.75	180.5
TB20035	200	35	245	145	120	55	37	M36x4.0	60	228	105	122	182.5	69	34	M16x2	193.5

• If the dimension and specification change, please take the confirmation drawing as a standard.

# TC series

## CLOSED CENTER HYDRAULIC CYLINDER (BUILT-IN CHECK VALVE & SWITCH BRACKETS)



- Built-in check valve.
- The bracket for proximity switch. (The proximity switches are extra option)

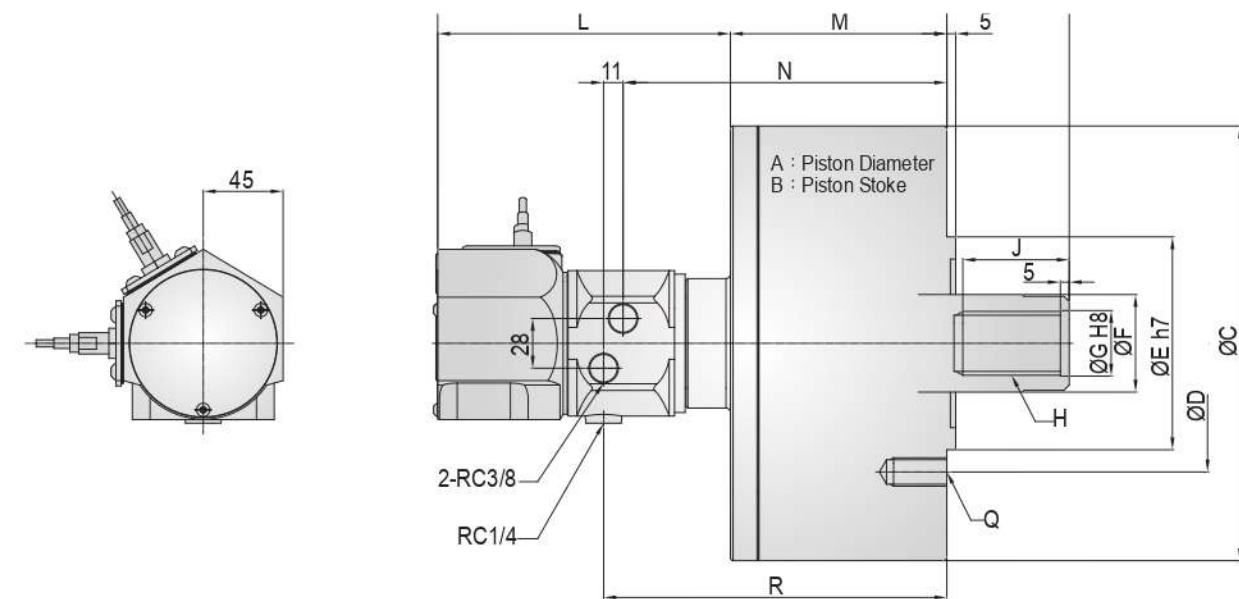

### SPECIFICATION

Model	Piston Area		Max. Push Force (kgf)	Max. Hydr. Pressure (kgf/cm <sup>2</sup> )	Oil Leakage Rate (l/min)	Max. Speed (r.p.m.)	Weight (kg)	Moment Of Inertia (kg.m <sup>2</sup> )
	Push Side (cm <sup>2</sup> )	Pull Side (cm <sup>2</sup> )						
TC10520	84	79	2960	41	0.8	6,000	8.5	0.013
TC12525	120	113	4285	41	0.8	6,000	11.5	0.023
TC15030	174	160	6120	41	0.8	5,500	14.5	0.048
TC20035	312	290	11015	41	0.8	5,500	37	0.122
TC25060	481.5	453.6	21825	50	2	2,000	78	0.85

• Push Force : Hydr. Pressure 41kgf/cm<sup>2</sup> • Oil Leakage Rate : Hydr. Pressure 30.6kgf/cm<sup>2</sup> and 50°C • Proximity switch : DC 12/24V 200mA NPN

### DIMENSIONS

Model	A Piston Diameter	B Piston Stroke	C	D	E (h7)	F	G (H8)	H	J	K	L	M	N	P (max)	P (min)	Q	R
TC10520	105	20	135	100	80	30	21	M20x2.5	35	255	165	91	152	45	25	M10x1.5	162.5
TC12525	125	25	160	130	110	35	25	M24x3.0	44	264	165	99	159.5	51	26	M12x1.75	107.5
TC15030	150	30	190	130	110	45	31	M30x3.5	45	274	165	109	169.5	56	26	M12x1.75	180.5
TC20035	200	35	245	145	120	55	37	M36x4.0	60	287	165	122	182.5	69	34	M16x2	193.5
TC25060	250	60	300	220	160	65	44	M42x3.0	60	362	185	178	220	85	25	M20x2	226

• If the dimension and specification change, please take the confirmation drawing as a standard.



# M series

## BOX JAWS (4PCS/ SET)

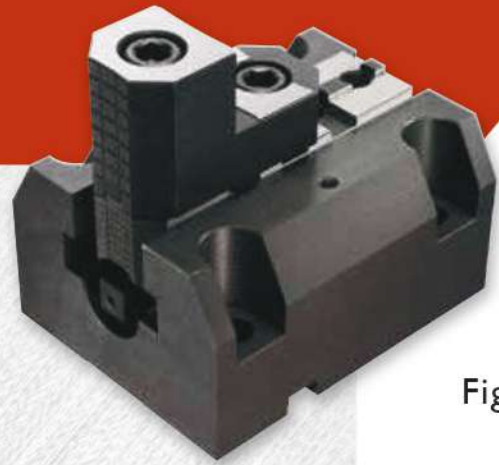

• Special specifications can be customized.

• Product Features : Different from the previous positioning of the box jaws by the positioning key, this product will positioning parts into the product, can be locked with the screw lock or unlock, can avoid the traditional positioning the possibility of flying out in the rotation and the advantage of easy assembly.

• Patent Number M417218

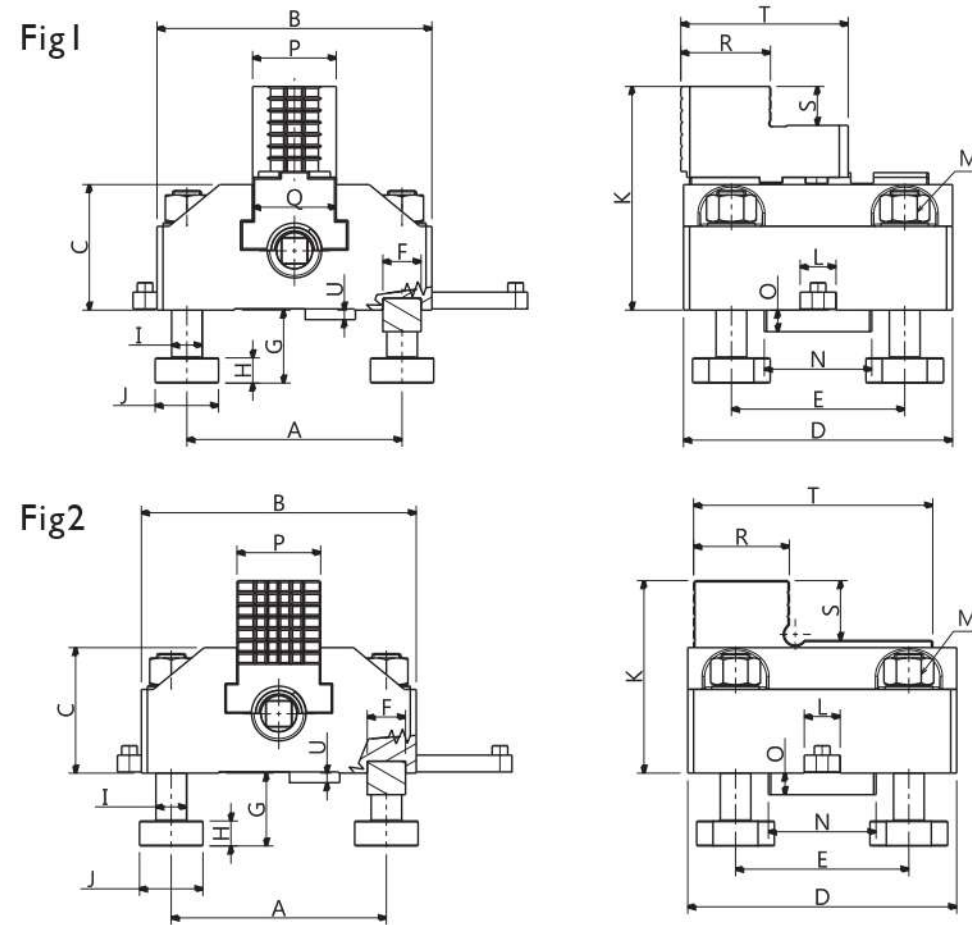

NEW  
PRODUCT

PATENT  
PROTECTED

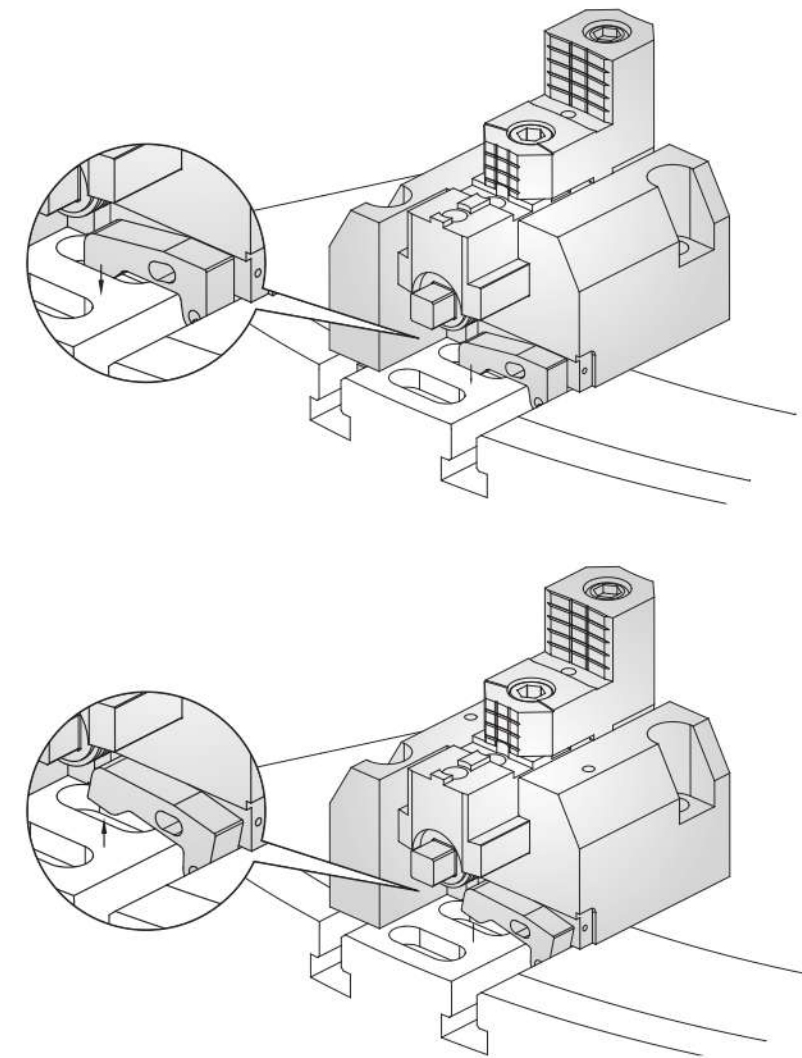

Model	A	B	C	D	E	F	G	H	I	J	K	L	M	N	O	P	Q	R	S	T	U	Reference Drawing
M125170-1	125	170	115	218	152.5	22	45	14	21.6	35	204	22	M20	75	6	63.5	56	59.4	48	135.4	4	Fig1
M125175-4-X1	125	175	100	225	145	22	41	14	21.6	36.5	189	22	M20	80	10	63.5	56	59.4	48	135.4	8.5	Fig1
M180230-5	180	230	105	225	145	32	61	21	25.6	53	187	30	M24	90	18	70	70	75	32.5	140	8	Fig1
M205250	205	250	109	218	143	22	45	14	21.6	35	198	22	M20	75	6	63.5	56	59.4	48	135.4	4	Fig1
M125170-4	125	170	100	218	152.5	22	45	14	21.6	35	156	22	M20	75	6	56	80	50	200	4	Fig2	
M125175-4	125	175	100	225	145	22	41	14	21.6	36.5	155	22	M20	80	10	56	80	50	200	8.5	Fig2	
M180230-6	180	230	105	225	145	32	61	21	25.6	53	161	30	M24	90	18	70	80	50	200	8	Fig2	
M205250-1	205	250	100	218	143	22	45	14	21.6	35	156	22	M20	75	6	56	80	50	200	4	Fig2	

• If the dimension and specification change, please take the confirmation drawing as a standard.

### NEW PRODUCT

Model	A	B	C	D	E	F	G (up)	G (down)	H	I	J	K	L	M	N	O	Reference Drawing
M125170-3	170	204	115	218	152.5	22	41	45	14	21.6	35	125	20	M20	50	6	Fig1
M125170-5	170	161	105	218	152.5	22	41	45	14	21.6	35	125	20	M20	50	6	Fig2
M205250-2	250	198	109	218	143	22	41	45	14	21.6	35	205	22	M20	75	6	Fig1
M205250-3	250	165	109	218	143	22	41	45	14	21.6	35	205	22	M20	75	6	Fig2

• If the dimension and specification change, please take the confirmation drawing as a standard.

# PD series

## HARD TOP JAWS

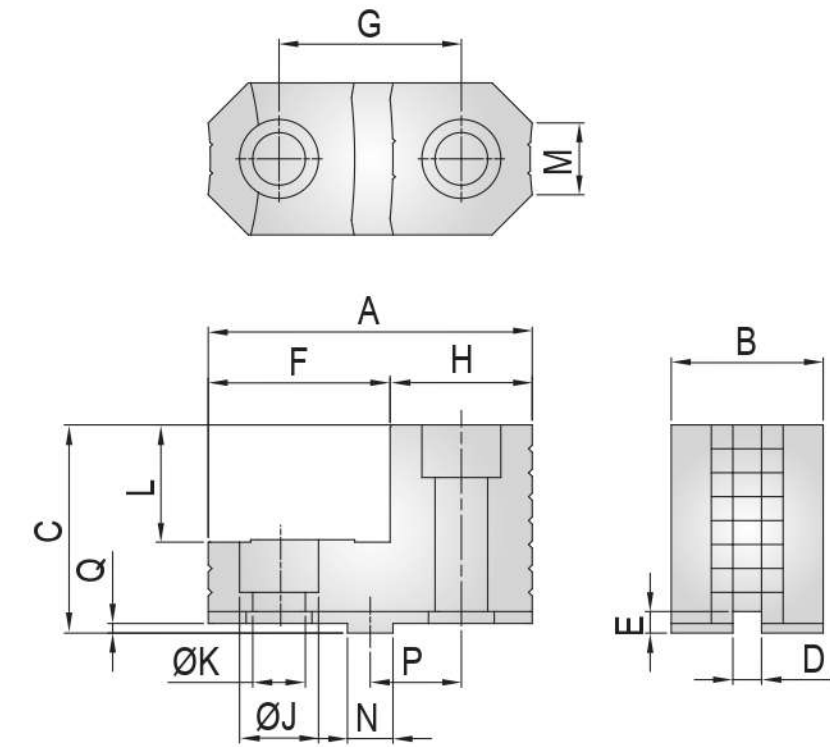
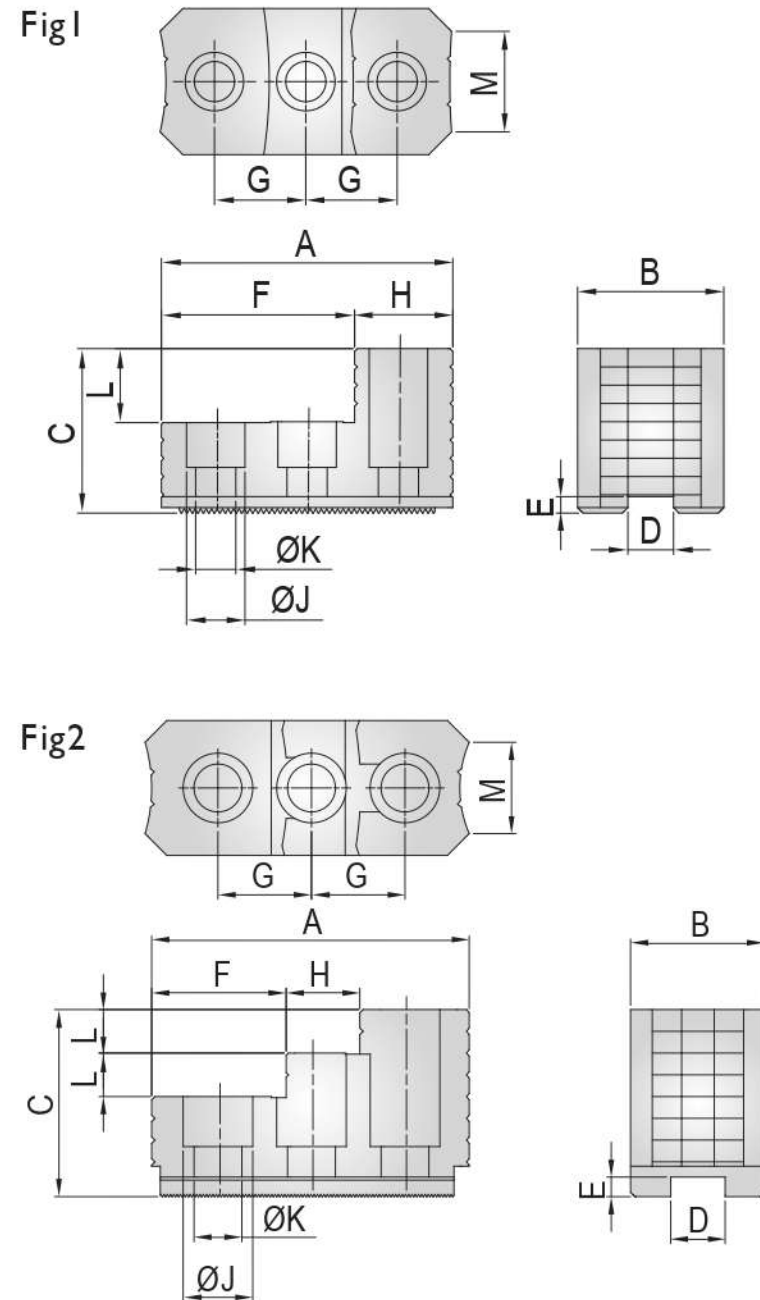

### SERRATION

Model	A	B	C	D	E	F	G	H	J	K	L	M	Serration Pitch	Reference Drawing	Weight (kg)
PD1-15	149	62	86	25.5	9	63	43	34	32	22	20	42	1.5*60°	Fig2	3.1
PD1-21-1	159.5	80	84	25	9	100	50	59.5	32	22	40	42	3.0*60°	Fig1	3.3
PD1-32-1	159.5	80	90	25	9	97.5	50	62	32	22	40	60	3.0*60°	Fig1	5.1

• If the dimension and specification change, please take the confirmation drawing as a standard.

### TONGUE & GROOVE

Model	A	B	C	D	E	F	G	H	J	K	L	M	N	P	Q	Weight (kg)
PD2-15-2	135.4	63.5	87	12	9	79	76.2	59.4	33	22	48	30	19.03	38.1	4	2.9
PD2-28-2	150	85	90	30	9	80	76.2	70	39	26	41	30	19.03	38.1	4	5
PD2-32-7	135.4	63.5	87	12	9	79	76.2	59.4	33	22	43	49.5	19.03	38.1	4	3.3
PD2-40-1	150	85	90	30	9	80	76.2	70	39	26	42.5	65	19.03	38.1	4	5
PD2-40-2	223	85	121	30	9	135	114.3	88	39	26	55	65	19.03	38.1	4	10.8
PD2-49-2	200	85	120	30	9	115	114.3	85	39	26	60	55	19.03	38.1	4	9.3
PD2-63-2	160	90	115	30	9	80	76.2	80	39	26	55	50	19.03	38.1	4	7.8

• If the dimension and specification change, please take the confirmation drawing as a standard.

# PE series

## SOFT TOP JAWS



PE1

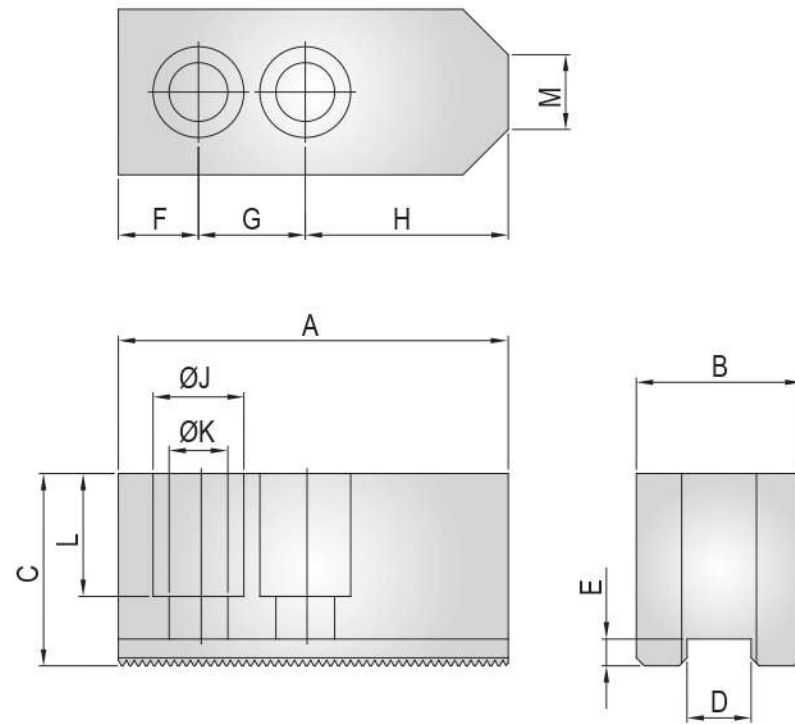

PE2

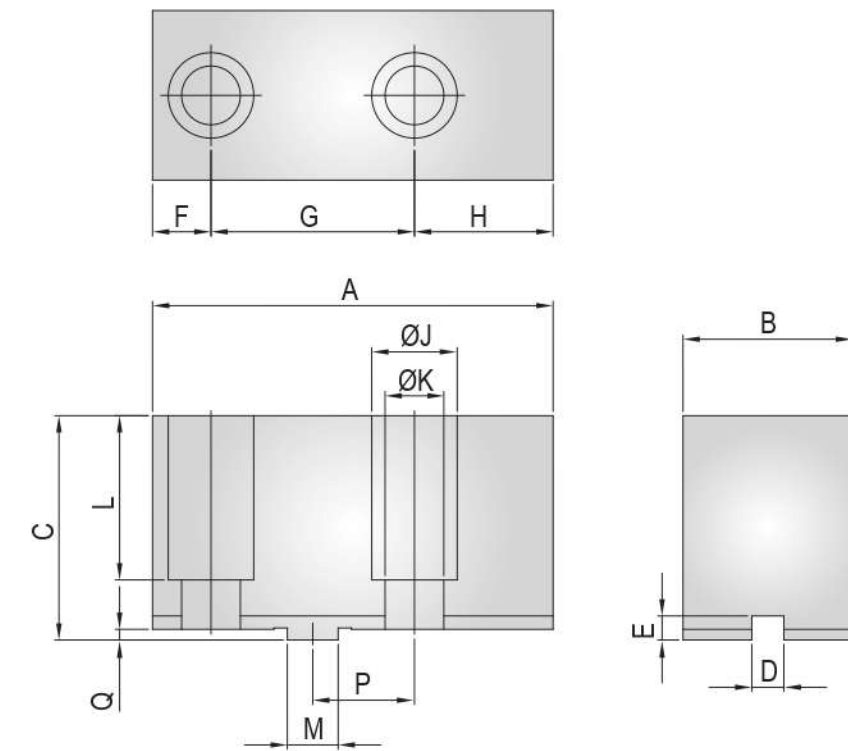

### SERRATION

Model	A	B	C	D	E	F	G	H	J	K	L	Serration Pitch	Weight (kg)
PE1-15-1	165	62	62	25.5	8	37	43	85	32	22	38	1.5°60°	4.1
PE1-15-2	160	65	70	25	9	25	50	85	32	22	45	3.0°60°	4.7
PE1-24-1	180	64	70	25	9	40	60	80	32	22	45	3.0°60°	5.3
PE1-32-1	210	74	90	25	9	40	60	110	32	22	65	3.0°60°	9.6

• If the dimension and specification change, please take the confirmation drawing as a standard.

### TONGUE & GROOVE

Model	A	B	C	D	E	F	G	H	J	K	L	M	P	Q	Weight (kg)
PE2-21-1	150	63.5	84	12	9	21.9	76.2	51.9	32	22	61.5	19.03	38.1	4	5
PE2-32	180	85	90	30	9	39.9	76.2	63.9	39	26	63.5	19.03	38.1	4	8.8
PE2-40	210	85	90	30	9	39.9	76.2	93.9	39	26	63.5	19.03	38.1	4	10.5
PE2-49	180	80	110	30	9	31.9	76.2	71.9	32	22	80	19.03	38.1	4	10.7
PE2-63-1	270	108	114	30	11	83.8	76.2	33.8	39	25	90	19.03	0	4	22

• If the dimension and specification change, please take the confirmation drawing as a standard.

# PM series

## ADAPTER PLATES

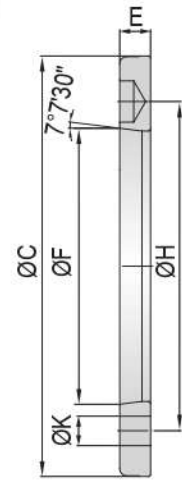

Type 1

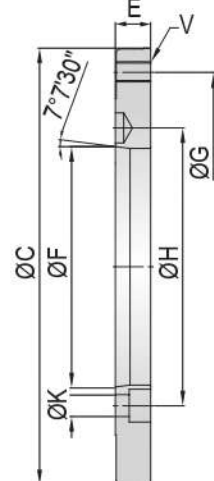

Type 2

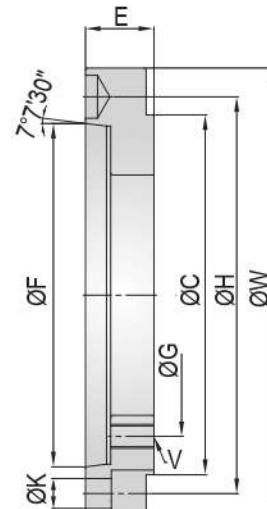

Type 3

### Type 1

Model	Spindle Noses	C	F	H	K	E
PM1A11	A11	300	196.869	235	21	22
PM1A11-1	A11	300	196.869	235	21	22
PM1A15	A15	380	285.775	330.2	25	27
PM1A20	A20	520	412.775	463.6	25	25
PM1A28	A28	720	584.225	647.6	33	25

### Type 2

Model	Spindle Noses	C	F	H	K	G	V	E
PM2A8	A8	300	139.719	171.45	17	235	M20	33
PM2A8-1	A8	380	139.719	171.45	17	330.2	M24	33
PM2A11	A11	380	196.869	235	21	330.2	M24	27
PM2A11-1	A11	520	196.869	235	21	463.6	M24	45
PM2A11-2	A11	380	196.869	235	21	330.2	M24	41
PM2A15	A15	520	285.775	330.2	25	463.6	M24	42

### Type 3

Model	Spindle Noses	C	F	H	K	G	V	W	E
PM3A11	A11	220	196.869	235	21	171.45	M16	278	50
PM3A15	A15	300	285.775	330.2	25	235	M20	378	57

• If the dimension and specification change, please take the confirmation drawing as a standard.

# PK series

## T-NUTS

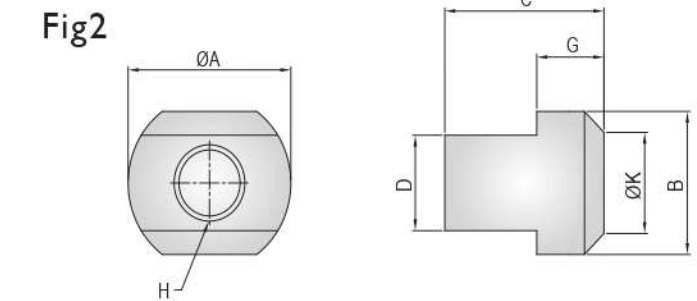
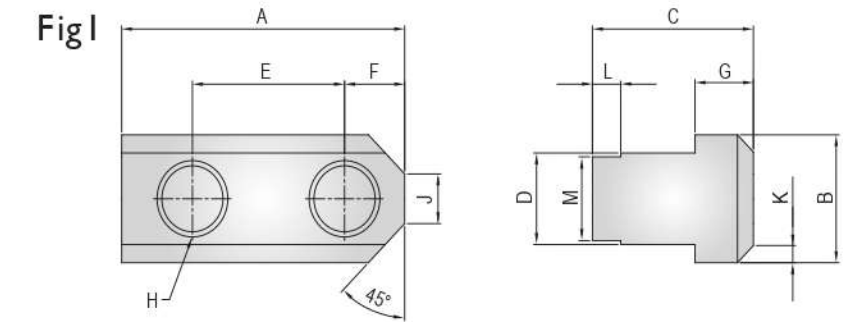

### DIMENSIONS

Model	A	B	C	D	E	F	G	H	J	K	L	M	Reference Drawing
PK2-15	80	33.5	45.5	24	43	17	16.5	M20	11	5	8	22	Fig1
PK3-15	42	35	39.2	25.5	-	-	19	M20	-	25	-	-	Fig2
PK3-24	46	37.5	45	25	-	-	19	M20	-	26.5	-	-	Fig2

• If the dimension and specification change, please take the confirmation drawing as a standard.

# PK5 series

## T-SCREWS

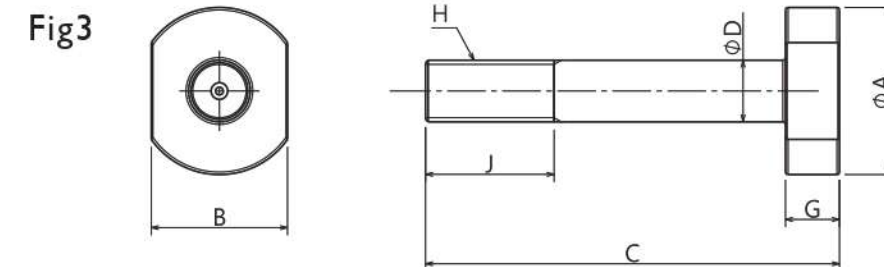

### DIMENSIONS

Model	A	B	C	D	E	F	G	H	J	K	L	M	Reference Drawing
PK5-M20127	51.5	36.5	141	21.6	-	-	14	M20	50	-	-	-	Fig3
PK5-M24140-2	65	53	161	24	-	-	21	M24	50	-	-	-	Fig3

• If the dimension and specification change, please take the confirmation drawing as a standard.